

## CUSTOM LOWER EXTREMITY ORDER FORM

Billing Information		Date
PO #		
Acct		
Bill To		
Attn		
Street		
City		
State	Zip	
CC#		
Exp	/	

Shipping Information		<input type="checkbox"/> Same as Billing
<input type="checkbox"/> Grnd (\$10) <input type="checkbox"/> 3 Day Air (\$25) <input type="checkbox"/> 2 Day (\$35) <input type="checkbox"/> O/N (\$65)		
Ship To		
Attn		
Street		
City		
State	Zip	

Contact Information	
Name	
Phone	(     )
Fax	(     )
Email	

C = CIRCUMFERENCE

L = LENGTH

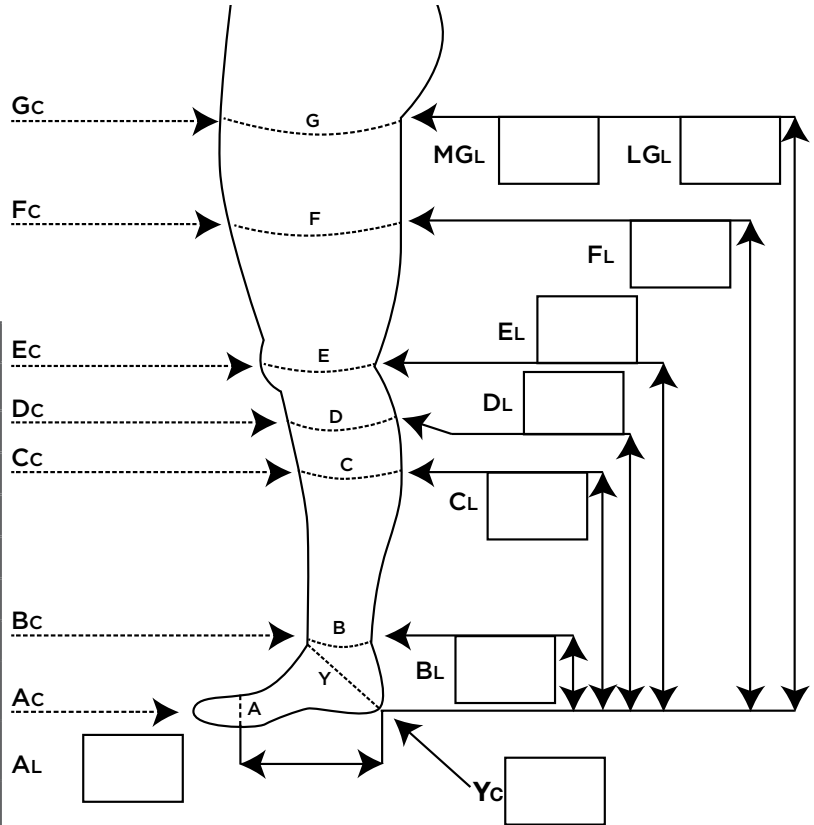

Item Code	Description	Black	Beige	Cost	Total
<b>ReadyWrap Custom Garments</b>					
Extremity: <input type="checkbox"/> Left <input type="checkbox"/> Right					
RW-LE-EG-C	Custom Thigh				
RW-LE-DE-C	Custom Knee				
RW-LE-BD-C	Custom Calf				
RW-LE-AB-C	Custom Foot				
RW-LE-AA-C	Custom Toe*				
<b>Silver Liners (standard sizes only) Not eligible for free garment option</b>					
LN-LE-AD	Below Knee				
LN-LE-AG-RG	Thigh High, Reg				
LN-LE-AG-MX	Thigh High, Max				
<b>Total</b>				<b>\$</b>	

Free Garment Option		Write QTY -One (1) per Eligible Garment
Silver Liner	QTY	<input type="checkbox"/> Below Knee <input type="checkbox"/> Thigh, Reg <input type="checkbox"/> Thigh, Max
<small>Single Garment</small>		

Patient Information	
Name	
<i>For Internal Use</i>	

\*Please include the ReadyWrap Custom Toe Form with your order. Not eligible for Free Garment Option

**Terms & Conditions:** Net 30 terms available for customers with approved credit applications. Other orders must be prepaid by check, MasterCard, Visa, or Discover.  
**Returns & Cancellations:** Please inspect your order immediately upon receipt. Defective products may be returned or exchanged within two weeks of delivery. Products returned which are not defective are subject to round-trip shipping charges and a restocking fee of 15%. Prices and policies are subject to change without prior notification.